

**Let's
talk about
what's
possible.™**

Vendor Display Guidelines.

Store Experience- FY26

What's New For FY26



Best Buy Canada's Vendor Display Guidelines are intended to help vendors build displays that are in conformance and compliance with Best Buy fixtures and store requirements.

If you are reviewing the guidelines prior to a project manager from Best Buy Canada being assigned to your project, these are for design development only. No manufacturing or production of any display should start until approval has been given by your assigned project manager.

Please review the project process on Page 6 for more information.

What's New For FY26

- Removed Best Buy Vendordisplayinquiries@bestbuycanada.ca from Guidelines. No longer in use (Page 6)
- Corrugate bulkout clarity on cardboard use and prepack requirements (Page 23)
- Vendor displays MUST have a removable backer. No exceptions (Page 10-11, 13-18)
- 12" wide displays are no longer accepted. Must be minimum 24" wide (Page 10-18)
- Power requirements from bottom of display or fed out the back (Page 43)
- Power supply requirements for small and large vendor displays (Page 43)
- Added new section for 4 foot gondola displays for deep shelves (Page 16)
- Any display signage should reference the entire Best Buy assortment online at Bestbuy.ca and should be approved by Best Buy (Page 10-33)
- Added Best Buy Express Vendor Display Guidelines (Page 24-33)
- Convergent removed and updated to SageNet (Page 45)
- Updated new Geek Squad Display Installation Services deck (Page 52+)

Table of Contents

Summary – Approval Process

Page 6

Display Shipping

Page 7

Pricing Strategy

Page 8 - 9

Display Requirements

Page 10-23

- G3 Table Endcap
- G3 Table Inline
- Platform Display (Table or Gondola)
- G8 Table Endcap and Inline
- G4 Table
- G4 Table- Small Appliance and Printers
- 4 FT Gondola Shelf Display- Appliances
- 4 FT Gondola Shelf Display
- 2 FT Gondola Shelf Display
- HT-E TV Endcap- Experience
- Low Bay Gondola
- Perimeter- Non-Experience
- Perimeter- Experience and Small Format
- Bulkouts

Page 10
Page 11
Page 12
Page 13
Page 14
Page 15
Page 16
Page 17
Page 18
Page 19
Page 20
Page 21
Page 22
Page 23

Table of Contents

Best Buy Express

- Table Endcap
- Table Inline
- Millwork Gondola
- Gondola Shelf Display
- Perimeter- Televisions
- Perimeter- All Remaining Sections
- Perimeter
- Hardware Shelf
- Headphones and Portable Audio

Page 24-33

Page 25
Page 26
Page 27
Page 28
Page 29
Page 30
Page 31
Page 32
Page 33

Appendix

- French Language Guidelines
- Retail Technology Guidelines- Digital Content
- Display Requirements
- Networking Requirements
- Display Maintenance
- Geek Square Display Installation Services

Page 34-59

Page 35-37
Page 38-42
Page 43-47
Page 48-50
Page 51
Page 52+

Summary- Approval Process

1. Vendor to share project proposal and design concepts with Best Buy Category Leader
2. Category Leader is to submit project request to Store Experience team for internal approval, space and display requirements, and PM assignment
3. Vendor to submit the following to Best Buy for approval:
 - Rendering of display fixture proposal
 - Fixture drawings with dimensions and material finishes
4. Best Buy Canada may request the vendor to produce a physical prototype of specific display elements for final review
5. Vendor must book an appointment with Best Buy contacts for shipping the prototype to a location specified by Best Buy Canada for review
 - Vendor to make all arrangements for display installation and coordinate dates with Best Buy
 - If display prototype needs to be imported into Canada, vendor will handle all arrangements for importation and be responsible for all customs fees
6. Best Buy to review the prototype and issue feedback to the vendor based on review
7. Vendor to implement feedback from Best Buy and re-submit to Best Buy for approval
8. Once final approval is issued, vendor to begin production and target delivery as per schedule provided by Best Buy

For any questions, please reach out to your Best Buy Category Leader.



Display Shipping

- Vendors are responsible for all shipping costs and associated customs/duty fees and taxes
- Vendor must always be importer of record if any display is coming from an international location
- Best Buy Store Design team to provide shipping locations and delivery date window
- All deliveries must be carefully packaged for safety and to simplify loading/unloading
- If a vendor partner chooses to use a carrier that does not provide accurate tracking information, the partner may be responsible for any costs associated with unexpected shipping delays
 - Costs may include additional store labour, electrician re-visits, extensions to equipment rentals, etc.
- Labeling requirements
 - Please ensure that every pallet is clearly labeled with the BBY provided shipping label, any shipments not properly labeled are at risk of being lost or refused
 - A sample shipping label is shown below

NEW VENDOR DISPLAY PRODUCT PROCESS TEAM
CONTENTS: NAME OF DISPLAY SOW: July 12, 2020
CONTACT INFORMATION: <small>Project Manager email@bestbuycanada.ca</small>

Project Shipment For Third Party Execution
Contents: What's in the box?
Contact Information: <small>(Project Manager) (Email) (Phone)</small>

Pricing Strategy- Big Box Stores/ Best Buy Express

The following guidelines apply for pricing strategy in all vendor in-store fixtures:

- All 'big box' store locations use a digital price tag/electronic shelf label system supplied by Pricer Inc. (company website: Pricer.com)
- Each product demo unit on display must have an adjacent price tag holder
- Vendors supply all price tag holders
- Price tag holders must support the following Pricer tag model types:
 - SmartTag HD Large - 3.6" wide x 1.6" high x 0.4" deep (small tag size)
 - SmartTag HD 150 - 5.9" wide x 4.7" high x 0.4" deep (fact tag size)
- **HD Large is the default tag size;** HD150 tag size is available as a purchased upgrade – contact your Best Buy Category Leader for details
- Vendor design proposal must indicate which tag sizes will be used and how they are mounted on the display
- Proposed pricing strategy must be approved by Best Buy Store Design team prior to full production
- Our recommendation is for price tag holders to sit on top of fixtures
 - Price rails can be inset in the fixtures
- Television displays to have SmartTag HD150 in black only



Pricing Strategy – Mobile SAS Locations

The following guidelines apply for pricing strategy in all vendor in-store fixtures:

- All Mobile SAS Locations use paper price tags
- Each product demo units on display must have an adjacent price tag holder
- Vendors supply all price tag holders
- Price tag holders must accommodate Best Buy standard price tag sizes:
 - 4.0" wide x 4.0" high (standard tag size)
 - 3.25" wide x 1.25" high (peg tag size)
- Vendor design proposal must indicate which tag sizes will be used and how they are mounted on the display
- Proposed pricing strategy must be approved by Best Buy Store Design team prior to full production
- Our recommendation is for price tag holders to be built to sit on top of fixtures
 - Price rails can be inset in the fixtures



1.25" high

3.25" wide

4.0" high

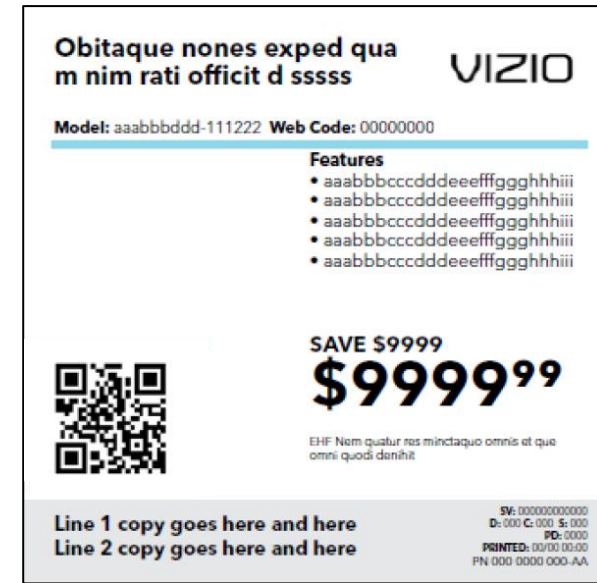

4.0" wide

Display Requirements- G3 Table Endcap

2.0 Display Presentation

- Full feature display as per diagram within dimensions of 35.875" length x 16.75" depth x 18" height
- Vendor to include in design price tag location
- Vendor to provide removable backer or use existing light box on table if available

2.1+ Display Presentation

- Full feature display as per above diagram within dimensions of 35.875" length x 16.75" depth x 18" height
- Vendor to include in design price tag location
- Vendor MUST provide removable backer or use existing sign holder if available
- Vendor must replace topper when they exit the space if they have removed it
- Vendor to provide adequate box stock with display roll out
- See power requirements on page 43
- Any display signage should reference the entire Best Buy assortment online at Bestbuy.ca and should be approved by Best Buy.



Best Buy will no longer accept 12" displays. Vendors must produce a minimum of 24" display width.

Changes Are Coming!

- Best Buy will be switching to proprietary plexi signage holders to make our sections more consistent. Vendors will be required to provide signage to install into the holder in lieu of providing a backer on the display.

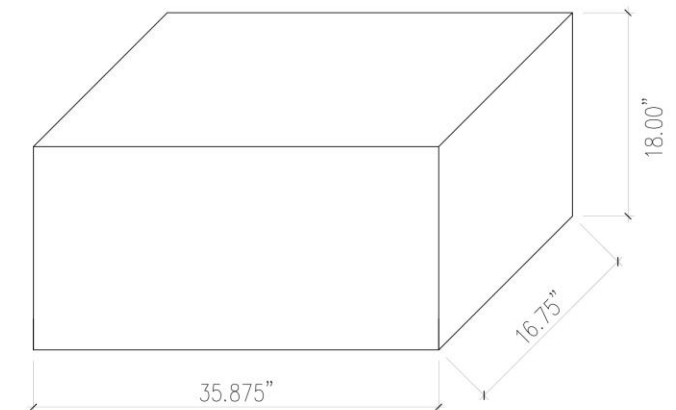

Display Requirements- G3 Table Inline

2.0 Display Presentation

- Full feature display as per above diagram within dimensions of 47.875" length x 12" depth x 18" height
- Vendor to include in design price tag location
- Vendor to provide removable backer or use existing light box on table if available

2.1+ Display Presentation

- Full feature display as per above diagram within dimensions of 47.875" length x 12" depth x 18" height
- Vendor to include in design price tag location
- Vendor MUST provide removable backer or use existing sign holder if available
- Vendor must replace topper when they exit the space if they have removed it
- Vendor to provide adequate box stock with display roll out
- See power requirements on page 43
- Any display signage should reference the entire Best Buy assortment online at Bestbuy.ca and should be approved by Best Buy.



Best Buy will no longer accept 12" displays. Vendors must produce a minimum of 24" display width.

Changes Are Coming!

- Best Buy will be switching to proprietary plexi signage holders to make our sections more consistent. Vendors will be required to provide signage to install into the holder in lieu of providing a backer on the display.



Display Requirements- Platform Display (Table or Gondola)

G3 table topper Display Presentation

- Convertible display option that can transition between gondolas and tables

Table Display Presentation

- Must include bolts, washers and wingnuts on the underside to attach to topper.
 - Vertically centered at 5.375" from front and back of display
 - Bolts between 3/8" - 1/2" and washers larger than 3/4" in diameter should be used
- Power must use a single cord/plug and run from the bottom of the display only
- Dimensions:
 - 2ft Display: 23.75" width x 12" depth x 2" max height of base
 - 4ft Display: 47.875" width x 12" depth x 2" max height of base
 - Total maximum height including product is 18"
- Display must have demo product, signage only will not be allowed

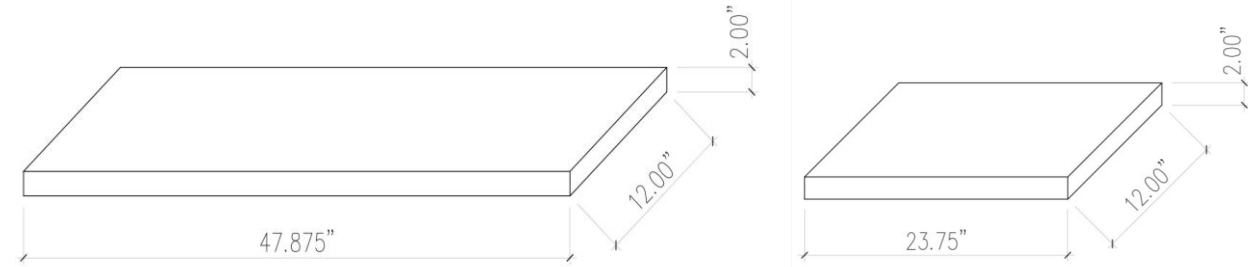

Gondola Display Presentation

- Use display base from table display and add in a backer
- Backer dimensions:
 - 2ft Display: 23.75" width x 1.25" depth(Backer) x 18" height x 12" Depth of overall display
 - 4ft Display: 47.875" width x 1.25" depth(Backer) x 18" height x 12" Depth of overall display
- Display must have demo product, signage only will not be allowed
- Any display signage should reference the entire Best Buy assortment online at Bestbuy.ca and should be approved by Best Buy.

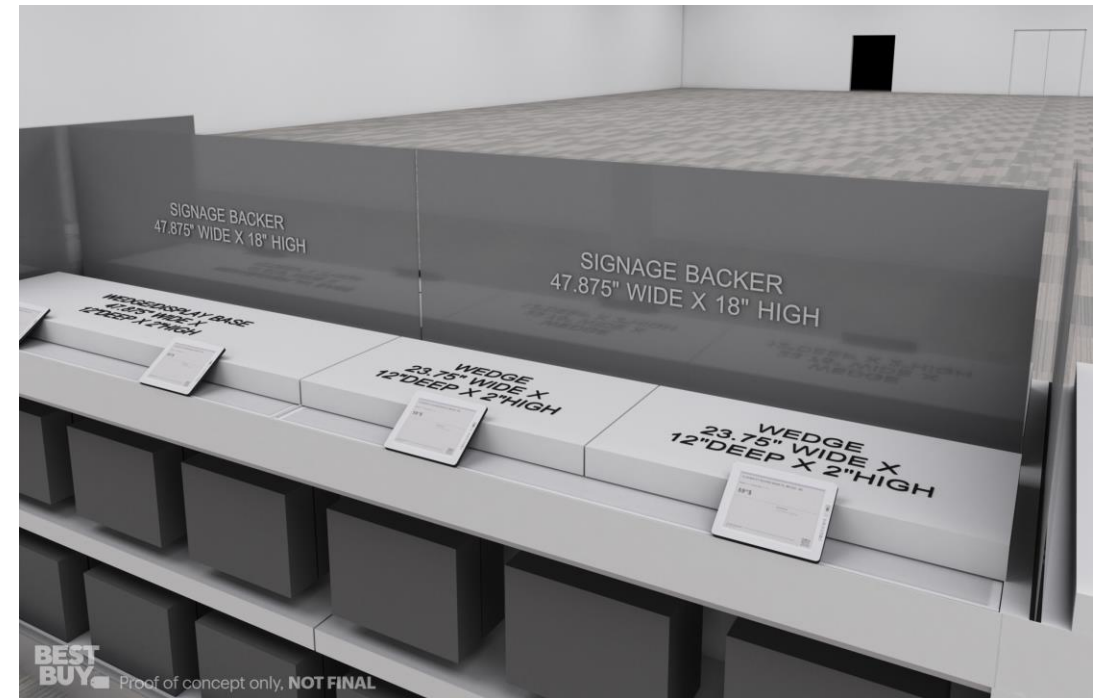

UNDERSIDE TOPPER VIEW

Best Buy will no longer accept 12" displays. Vendors must produce a minimum of 24" display width.

Display Requirements- G8 Table Endcap and Inline



Display Presentation

- Full feature display as per above diagram with dimensions of 47.875" length x 16.75" depth x 18" height
- Vendor to include in design price tag location
- Vendor MUST provide removable backer or use existing sign holder if available

- Vendor must replace topper when they exit the space if they have removed it
- See power requirements on page 43
- Any display signage should reference the entire Best Buy assortment online at Bestbuy.ca and should be approved by Best Buy.

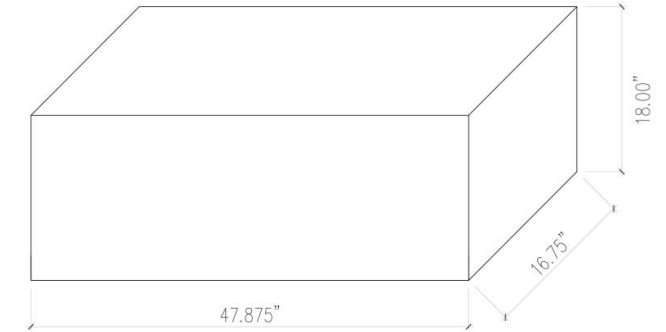

Changes Are Coming!

- Best Buy will be switching to proprietary plexi signage holders to make our sections more consistent. Vendors will be required to provide signage to install into the holder in lieu of providing a backer on the display.

Best Buy will no longer accept 12" displays. Vendors must produce a minimum of 24" display width.

Display Requirements- G4 Table

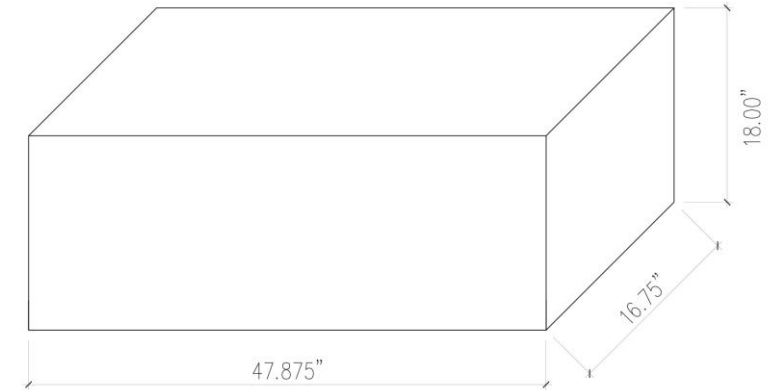

Display Presentation

- Full feature display as per above diagram with dimensions of 47.875" length x 16.75" depth x 18" height
- Display can be branded to vendor's discretion. Lighting can also be incorporated into the display with power cord exiting from the rear (See Display Requirements- Power & Lighting)
- Vendor to include in design price tag location
- Vendor MUST provide removable backer or use existing sign holder if available

- Vendor must replace topper when they exit the space if they have removed it
- See power requirements on page 43
- Any display signage should reference the entire Best Buy assortment online at Bestbuy.ca and should be approved by Best Buy.

Changes Are Coming!

- Best Buy will be switching to proprietary plexi signage holders to make our sections more consistent. Vendors will be required to provide signage to install into the holder in lieu of providing a backer on the display.

Best Buy will no longer accept 12" displays. Vendors must produce a minimum of 24" display width.

Display Requirements- G4 Table- Small Appliance and Printers

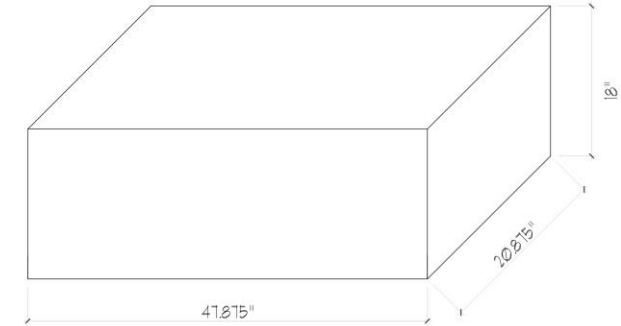
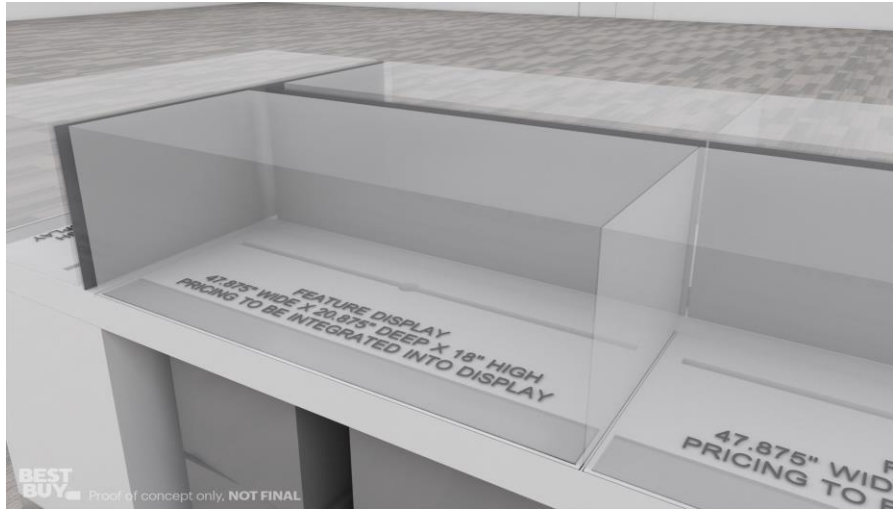

Display Presentation

- Full feature display as per above diagram with dimensions of 47.875" length x 20.875" depth x 18" height
- Display can be branded to vendor's discretion. Lighting can also be incorporated into the display with power cord exiting from the rear (See Display Requirements- Power & Lighting)
- Vendor to include in design price tag location
- Vendor MUST provide removable backer or use existing sign holder if available
- Vendor must replace topper when they exit the space if they have removed it
- See power requirements on page 43
- Any display signage should reference the entire Best Buy assortment online at Bestbuy.ca and should be approved by Best Buy.

Changes Are Coming!

- Best Buy will be switching to proprietary plexi signage holders to make our sections more consistent. Vendors will be required to provide signage to install into the holder in lieu of providing a backer on the display.

Best Buy will no longer accept 12" displays. Vendors must produce a minimum of 24" display width.

Display Requirements- 4 FT Gondola Shelf Display- Appliance

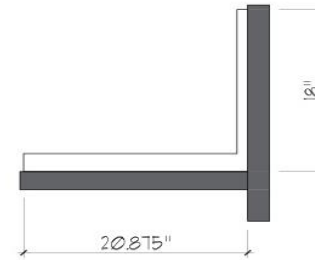
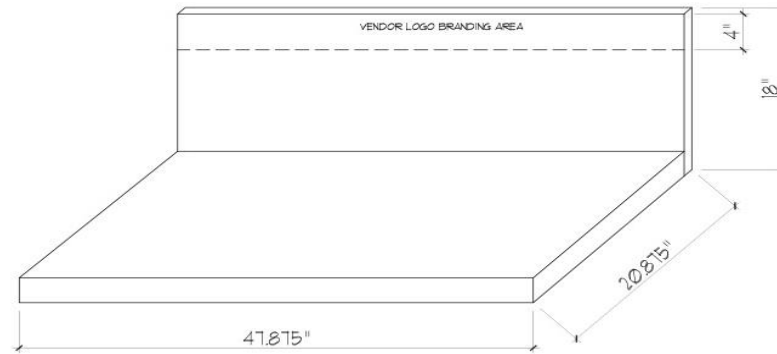

Display Presentation

- Gondola shelf display design is used for typical Best Buy gondola fixtures that are 24" deep. Only for appliances.
- Maximum display dimensions are 47.875" wide x 18" tall x 20.875" deep
- Existing Best Buy Header to be removed
- Vendor to include in design price tag location
- Vendor MUST provide removable backer
- Any display signage should reference the entire Best Buy assortment online at Bestbuy.ca and should be approved by Best Buy.
- See power requirements on page 43

Best Buy will no longer accept 12" displays. Vendors must produce a minimum of 24" display width.

Best Buy will provide price tag holders for the first row of product on the display

- Any additional rows beyond the first row will require price tag holders incorporated into the display

Display Requirements- 4 FT Gondola Shelf Display

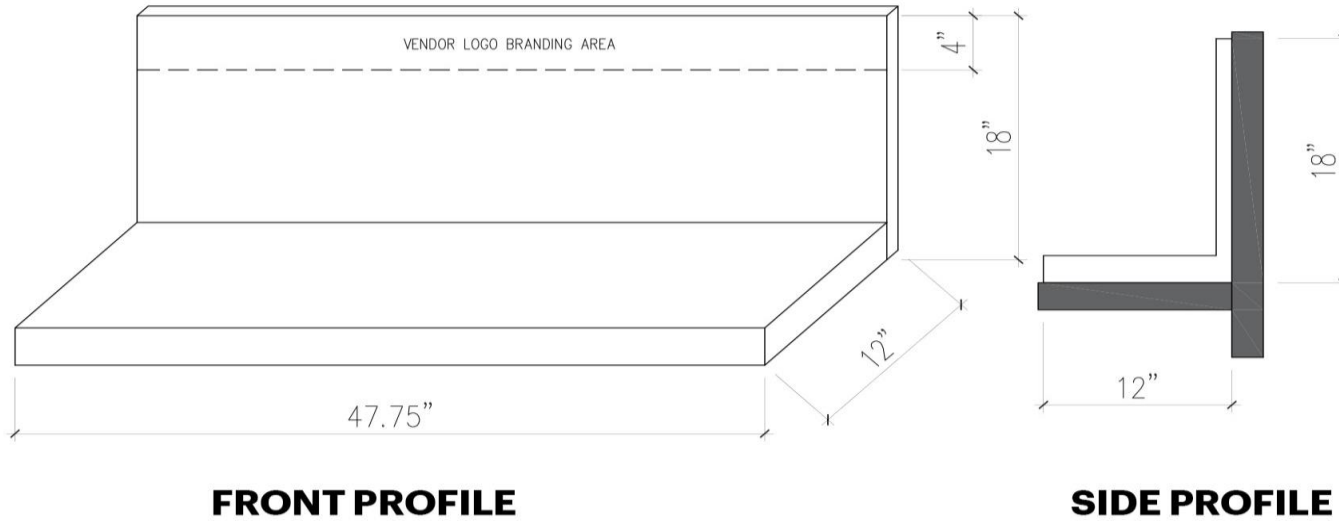

FRONT PROFILE

SIDE PROFILE

Display Presentation

- Gondola shelf display design is used for typical Best Buy gondola fixtures
- Maximum display dimensions are 47.75" wide x 18" tall x 12" deep
 - Note: Computing accessories displays to be maximum 12" High
- Existing Best Buy Header to be removed
- Vendor to include in design price tag location
- Vendor MUST provide removable backer
- Any display signage should reference the entire Best Buy assortment online at Bestbuy.ca and should be approved by Best Buy.
- See power requirements on page 43

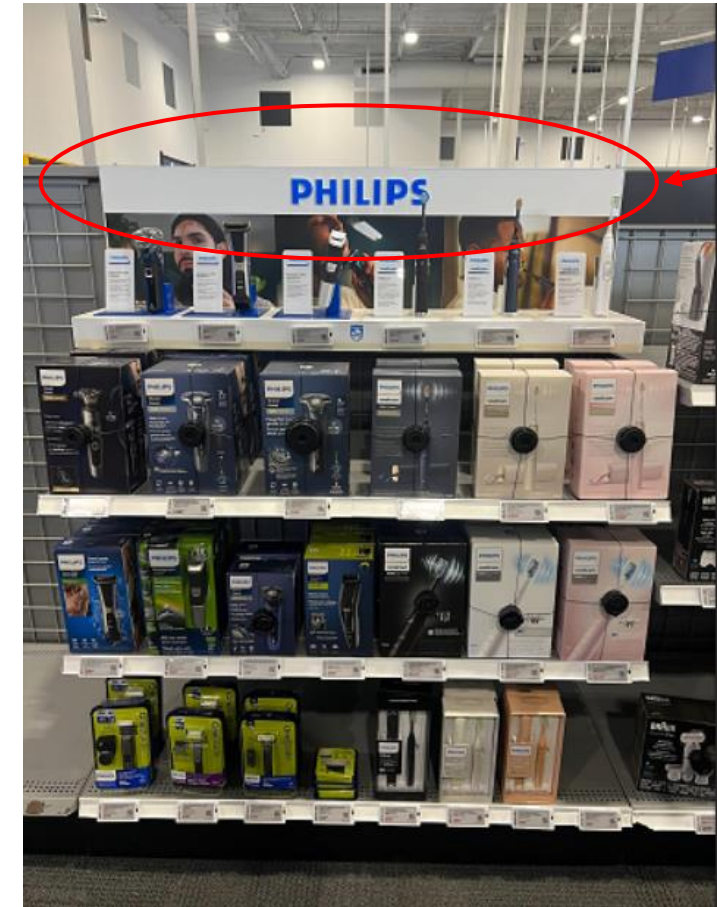

Vendor Logo Branding To Be 4" In Height

Best Buy will no longer accept 12" displays. Vendors must produce a minimum of 24" display width.

Best Buy will provide price tag holders for the first row of product on the display

- Any additional rows beyond the first row will require price tag holders incorporated into the display

Display Requirements- 2 FT Gondola Shelf Display

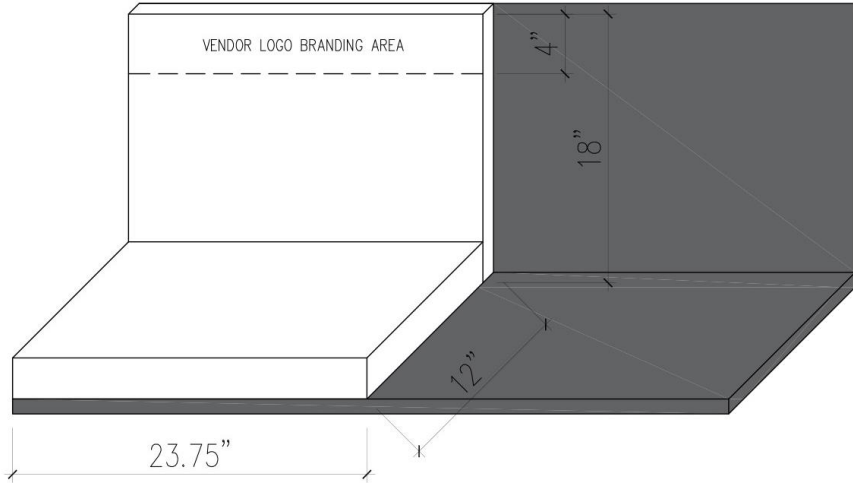

FRONT PROFILE

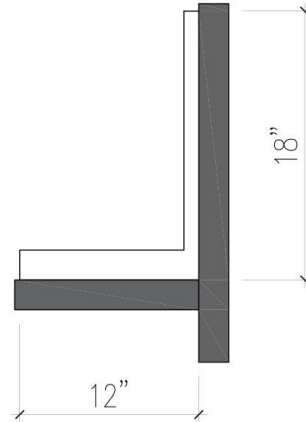

SIDE PROFILE

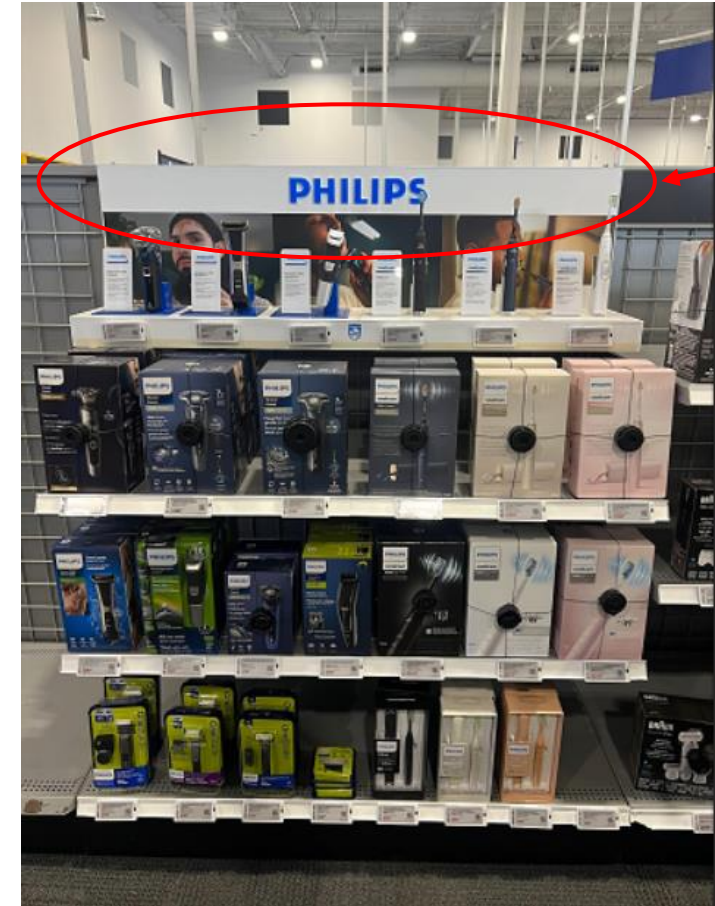

**Vendor Logo
Branding To Be
4\"/>**

Display Presentation

- Gondola shelf display design is used for typical Best Buy gondola fixtures
- Maximum display dimensions are 23.75" wide x 18" tall x 12" deep
 - Note: Computing accessories displays to be maximum 12" High
- Existing Best Buy header to be removed
- Vendor to include in design price tag location
- Vendor MUST provide removable backer
- Any display signage should reference the entire Best Buy assortment online at Bestbuy.ca and should be approved by Best Buy.
- See power requirements on page 43

**Best Buy will no longer accept 12" displays.
Vendors must produce a minimum of 24"
display width.**

Best Buy will provide price tag holders for the first row of product on the display

- Any additional rows beyond the first row will require price tag holders incorporated into the display

Display Requirements- HT-E TV Endcap- Experience



Display presentation

- Vendor to design a product display or dress kit that attaches to the endcap via slotted upright hooks
- Display proposal to fit within fixture interior dimensions
- Section backer must be covered with vendor branding
- Any display signage should reference the entire Best Buy assortment online at [Bestbuy.ca](https://www.bestbuy.ca) and should be approved by Best Buy.

Display Restrictions

- Height: 69"
- Depth: 9" Maximum (Cannot protrude past base deck. Base deck cannot be removed)
- Width: 54.125"

Basedeck dimensions

- 54.125"W x 4"H x 9"D Maximum

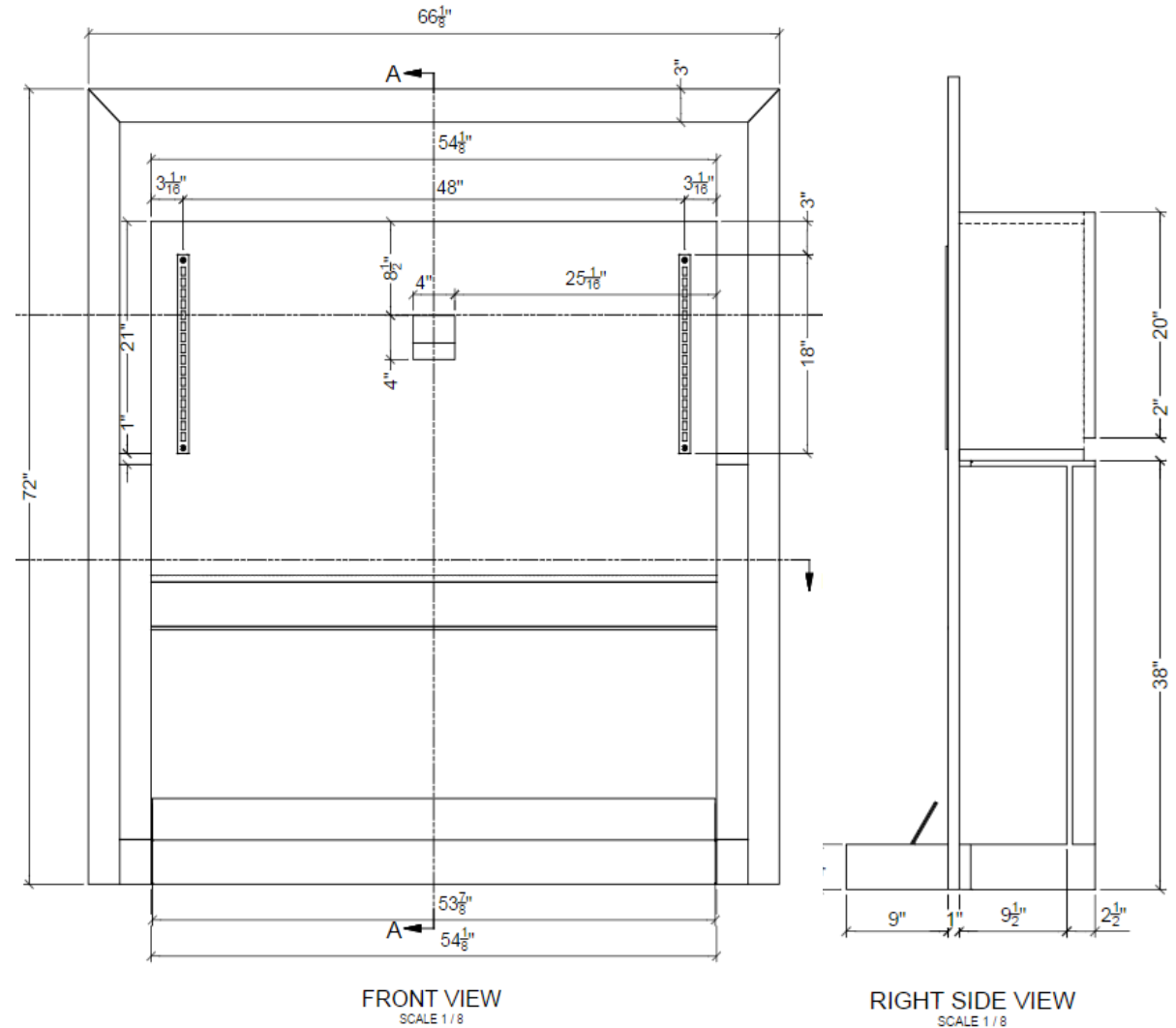

Display Requirements- Low Bay Gondola

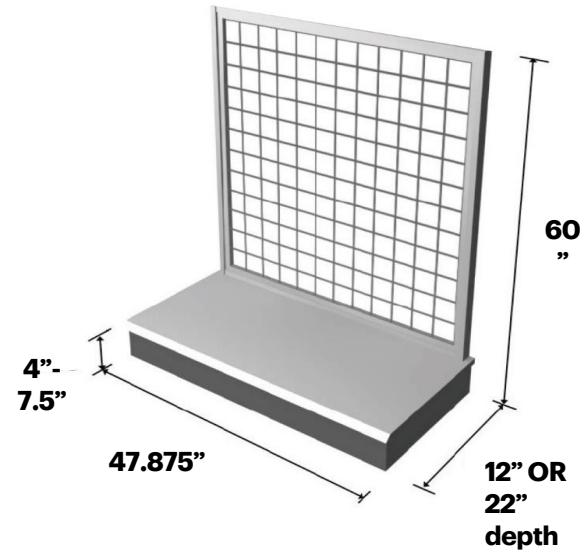

Full-size display restrictions (48" Inline & End Cap)

- Height: 52"
- Depth: 12" – 22"
- Width: 47.875" (center of one slotted upright to the next)
- Any display signage should reference the entire Best Buy assortment online at [Bestbuy.ca](https://www.bestbuy.ca) and should be approved by Best Buy.

Depth variations

- 12" – universal fit on all gondola types
- 22" – deep fixtures on wall/selected inline gondolas
- Total fixture height above finished floor (AFF): 60"
- Base deck cannot be removed
- Please confirm depth and height with your PM

Slotted Upright Detail

- Applicable for all gondola fixtures and Experience 1.0 pylon fixtures

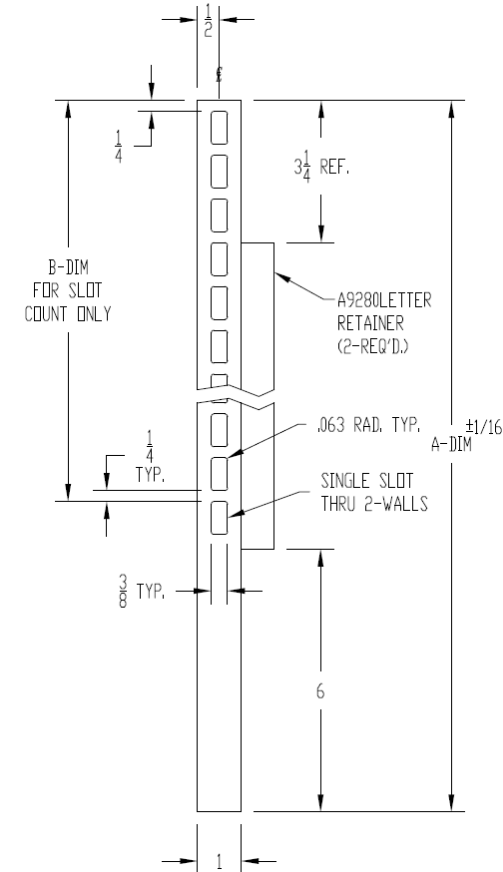

Slotted uprights must be used for attaching full-size display fixtures to low bay gondola sections. Full-size displays are defined as units that occupy the full 52" height of the gondola section.

Grid type varies between Existing BBY / New BBY (or completely absent in Experience stores) and an upright attachment system ensures proper fit for all store types.

Display Requirements- Perimeter- Non-Experience

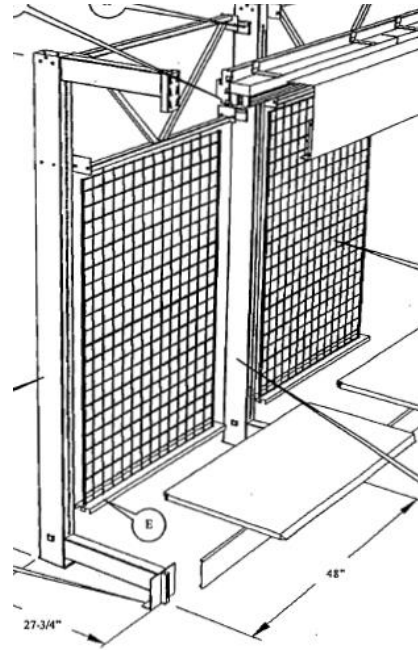

Perimeter Racking
(New BBY and Existing BBY)

4 New BBY stores (600, 701, 708, 749) have a
 - 19" base deck depth
 - 2 x 3" Spec for slotted uprights similar to AW-48
 - 11 Gauge uprights

Full-size display restrictions (48" Perimeter Fixtures)

- Height: 64 5/8" - 88 3/4"
- Depth: 24 or 28"
- Width: 47.875" (center of one slotted upright to the next)
- Total fixture height above finished floor (AFF): 96"
- Best Buy recommends including adjustable shelves that can slide within an inch or either side
- Any display signage should reference the entire Best Buy assortment online at Bestbuy.ca and should be approved by Best Buy.
- Please confirm depth with your PM

Slotted Upright Detail

- 11 Gauge uprights

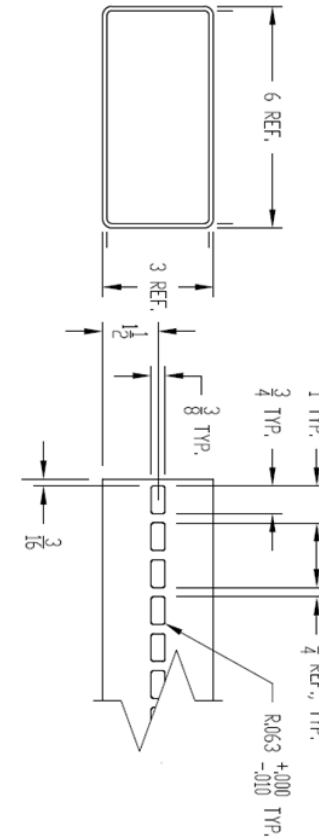

Slotted uprights must be used for attaching full-size display fixtures to low bay gondola sections. Full-size displays are defined as units that occupy the full 64" - 88" height of the perimeter section.

Grid type varies between Existing BBY / New BBY (or completely absent in Experience stores) and an upright attachment system ensures proper fit for all store types.

Display Requirements- Perimeter- Experience and Small Format

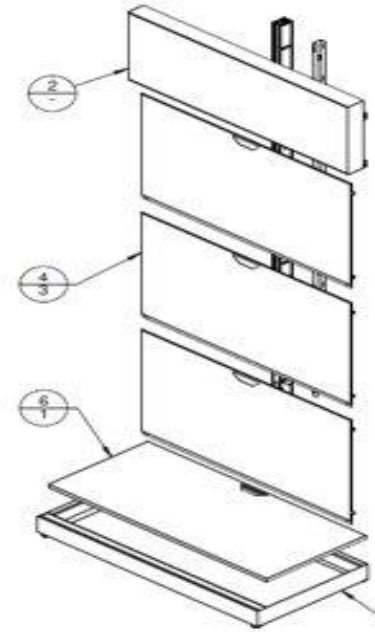

Perimeter Racking (AW-48)

Full-size display restrictions

- Height: 64 5/8" - 88 3/4"
- Depth: 24"
- Width: 47.875" (centre of one slotted upright to the next)
- Depth of base deck cover: 24"
- Total fixture height above finished floor (AFF): 95.875"
- Lightbox should have vendor logo fabric provided by vendor
- Any display signage should reference the entire Best Buy assortment online at Bestbuy.ca and should be approved by Best Buy.

Slotted Upright Detail

7 gauge on AW-48
8 gauge on MW-48

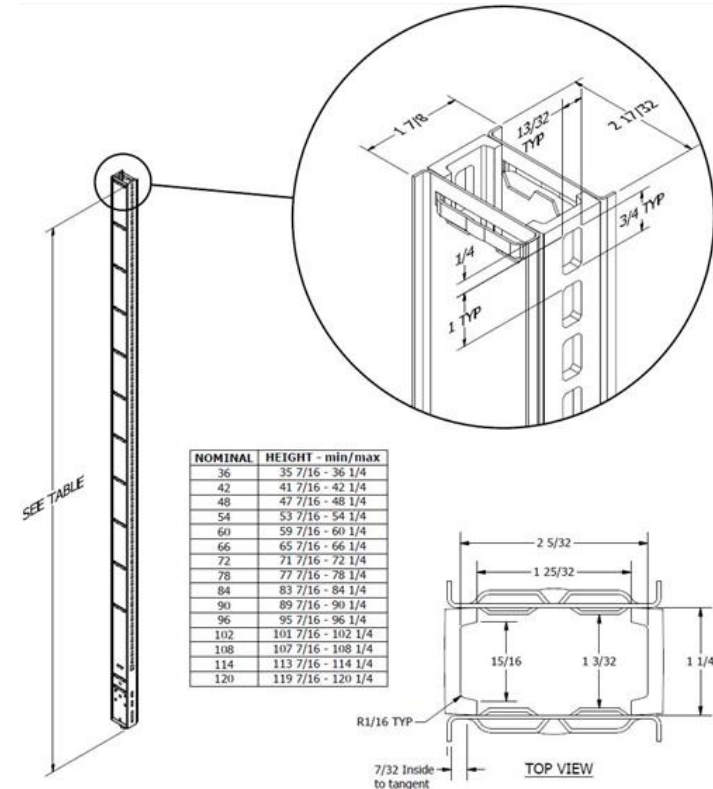

Display Requirements- Bulkouts

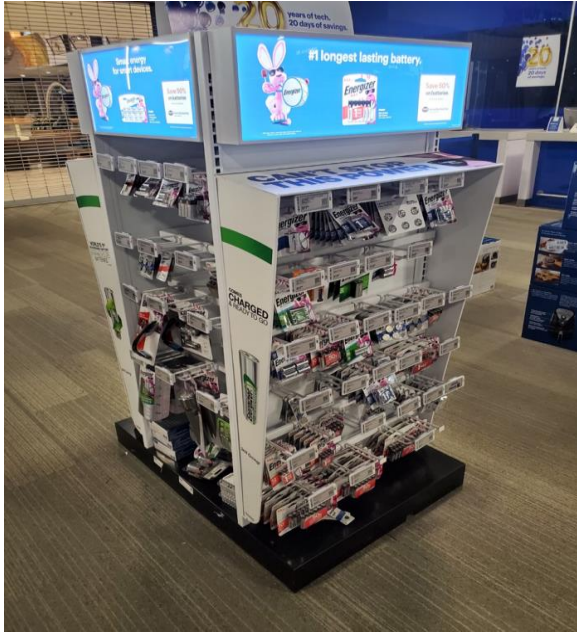

Display presentation

- Display locations may be rotated on a quarterly basis. Please contact your Best Buy Category Leader to confirm placement and availability.
- Display must include a pricing solution
- These guidelines only apply to vendors creating their own bulkout display fixtures. Vendors may also choose to use a Best Buy provided fixture, but fixtures are limited. Please contact your Best Buy Category Leader to confirm availability.
- If bulkout has electrical requirements, power must be provided from floor (only stores with raised access flooring)
- Any display signage should reference the entire Best Buy assortment online at [Bestbuy.ca](https://www.bestbuy.com) and should be approved by Best Buy.

Display restrictions

- Height: 60"
- Depth: up to 30"
- Width: up to 30"

Corrugate Bulkouts:

- May ONLY be used in stores during high volume sales periods such as back to school and the holidays
- Display must fall within these dimensions:
 - Height: up to 60"
 - Depth: up to 30"
 - Width: up to 30"
- Display must include a pricing solution (details can be found on pg. 5)
- Must be replaced every 3 weeks or sooner if the fixture is damaged at the vendor's expense
- Corrugate bulkouts must be rigid and solid to last the 3 week period. Replacements for any damage must be provided by vendor.
- Corrugates MUST be prepacked prior to store receiving. Stores will not merchandise corrugate bulkouts.

**Let's
talk about
what's
possible.™**

Best Buy Express

Best Buy Express- Table End Cap

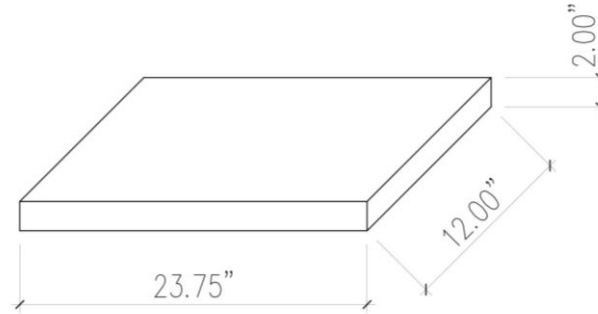
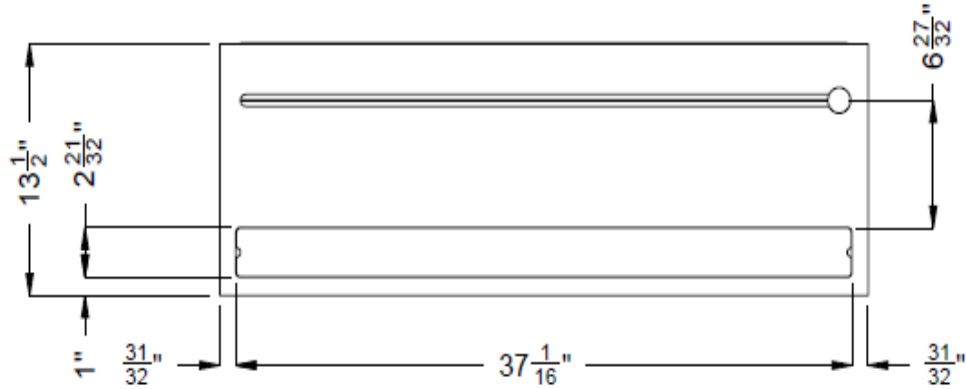

Display Presentation

- For laptops, smart home, and wearable categories
- Vendor display to consist of demo SKUs on small riser (12" deep x 2" high)
- Riser width will depend on individual products, but will not exceed 39" in width
 - Must include bolts, washers and wingnuts on the underside to attach to topper
- Each section is 39" wide with track for cable passthrough and securing displays to the table
 - Cable passthrough details above
- Vendor to include in design price tag location
- Vendor to provide signage for backer
 - Signage size 36.8125 " x 14.75 " (visible area: 35.3125 x 13.25)
 - Sign holder is a lightbox. Must be printed on SKYFILM or similar substrate
- See power requirements on page 43
- Any display signage should reference the entire Best Buy assortment online at [Bestbuy.ca](https://www.bestbuy.ca) and should be approved by Best Buy



Best Buy Express- Table Inline

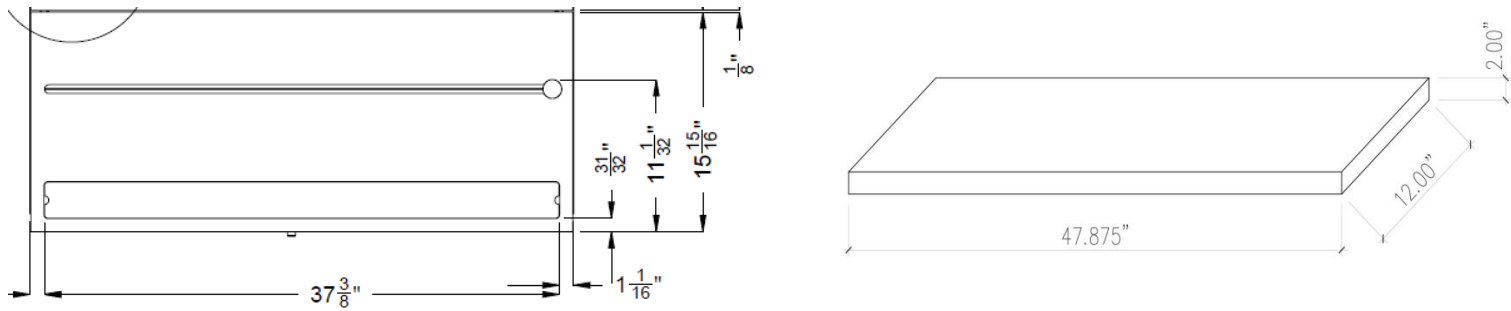

Display Presentation

- For laptops, smart home, and wearable categories. Base fixture within each category is the same, with signage and lockup differing between each.
- Vendor display to consist of demo SKUs on small riser (12" deep x 2" high)
- Riser width will depend on individual products, but will not exceed 39" in width
 - Must include bolts, washers and wingnuts on the underside to attach to topper
- Each section is 39" wide with track for cable passthrough and securing displays to the table
 - Cable passthrough details above
- Vendor to include in design price tag location
- Inline computing hardware
 - Accessory cross merch under tabletop – no lock up present
 - No signage holder
- Vendor to provide signage for backer
 - Confirm dimensions with your PM
 - Sign holder is a lightbox. Must be printed on SKYFILM or similar substrate
- See power requirements on page 43
- Any display signage should reference the entire Best Buy assortment online at [Bestbuy.ca](https://www.bestbuy.ca) and should be approved by Best Buy



Best Buy Express- Millwork Gondola

Display Presentation

- For small vendor displays for placement on shelves
- Maximum display dimensions are 24" wide x 12" tall x 12" deep or 48" wide x 12" tall x 12" deep
 - Displays cannot protrude past the base deck
- Millwork gondola have 42" of vertical merchandisable space
- Vendor to include in design price tag location
- See power requirements on page 39
 - Power is located under the top cap of the gondola
- Any display signage should reference the entire Best Buy assortment online at [Bestbuy.ca](https://www.bestbuy.ca) and should be approved by Best Buy

Endcap Information

- No displays allowed due to depth
- Peg product only
- 28" wide x 42" tall x 7" deep

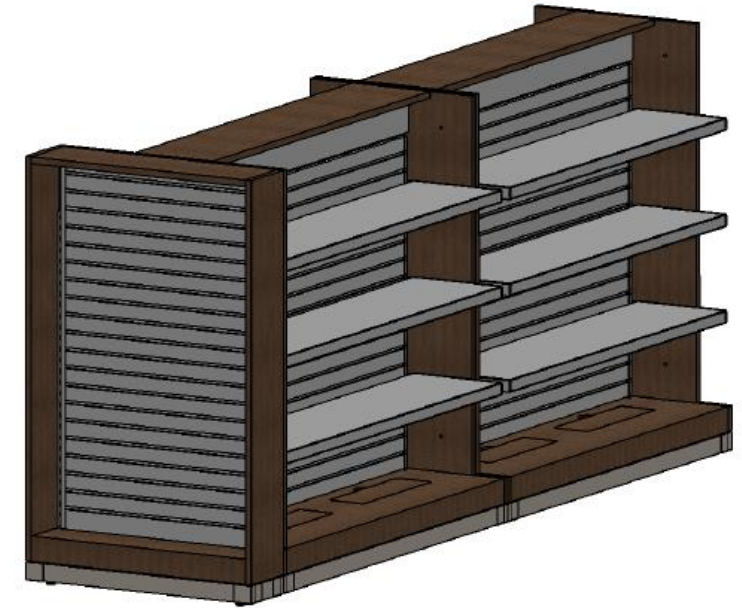

Best Buy Express- Gondola Shelf Display

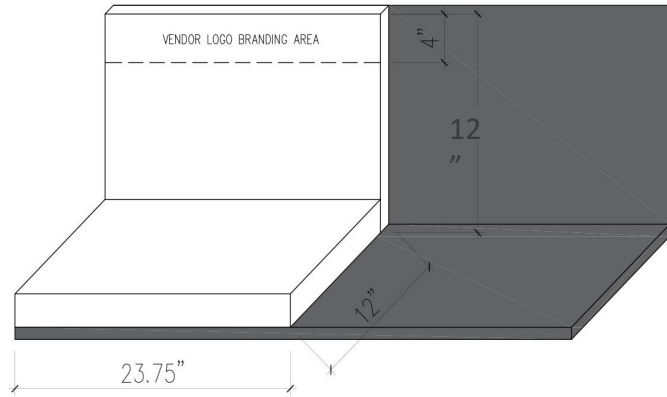

FRONT PROFILE

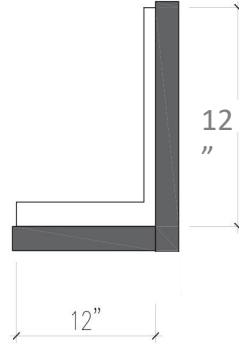

SIDE PROFILE

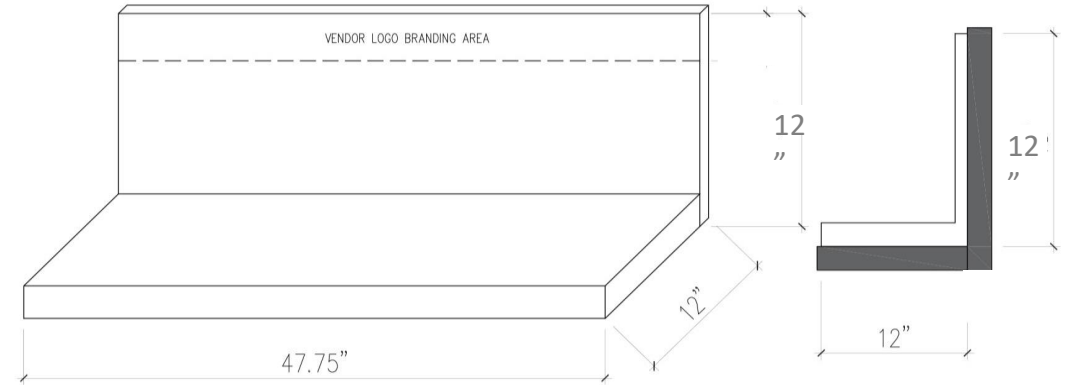

FRONT PROFILE

SIDE PROFILE

Display Presentation

- Gondola displays to be interchangeable between millwork gondola and metal gondola
- Maximum display dimensions are 23.75" wide x 12" tall x 12" deep or 47.875" wide x 12" tall x 12" deep
- Vendor to include in design price tag location
- See power requirements on page 43
- Any display signage should reference the entire Best Buy assortment online at Bestbuy.ca and should be approved by Best Buy

Best Buy will provide price tag holders for the first row of product on the display

- Any additional rows beyond the first row will require price tag holders incorporated into the display

Best Buy Express- Perimeter- Televisions

Display presentation

- Full feature display as per diagram with dimensions of 47.875" width x 16" depth (at base) and a max height of 97"
- Full vendor takeover of the section is allowed
 - Category sign, 16" high, must be included in the display
 - Triple slotted uprights span 96"h from basedeck with spacing at 48" on centre.
 - Display weight must be transferred through to the floor
 - Basedeck can be removed if needed
 - Plasma rails to hang TVs are not available through Best Buy
- Display can be branded to vendor's discretion. Lighting can also be incorporated into the display with power cord exiting from the rear (See Display Requirements - Power & Lighting)
- Vendor to include in design price tag location
- Any display signage should reference the entire Best Buy assortment online at Bestbuy.ca and should be approved by Best Buy

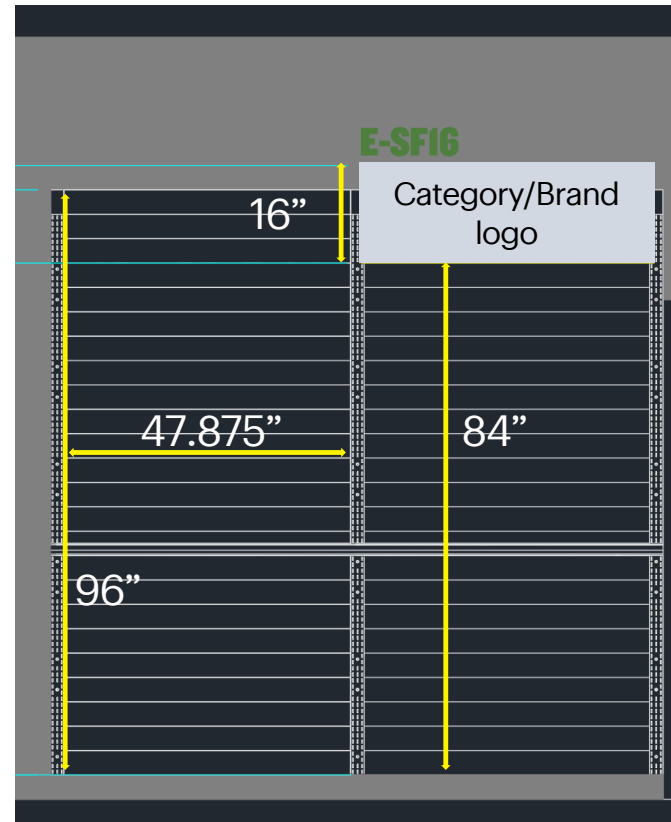

Slotted Upright Detail

- Applicable to all perimeter Best Buy Express sections

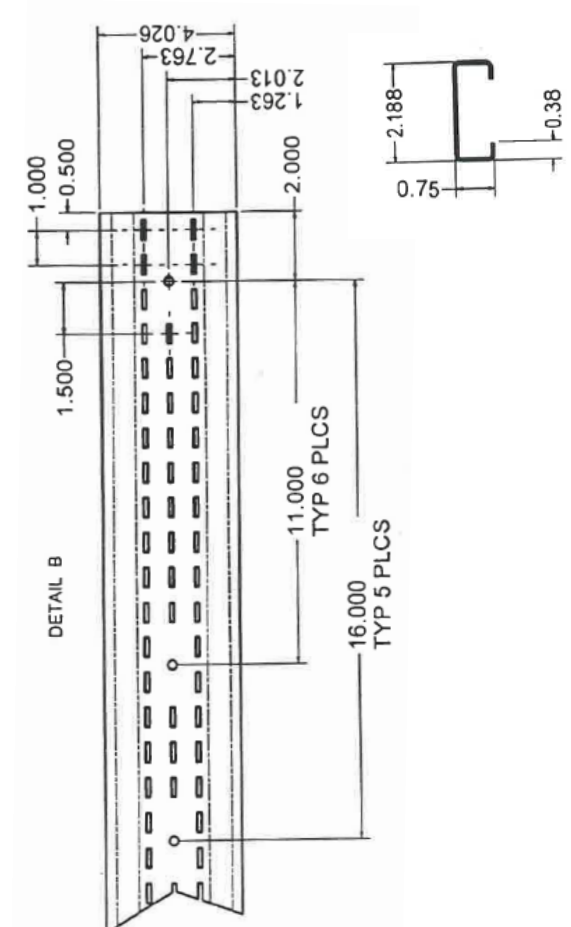

Best Buy Express- Perimeter- All Remaining Sections

Display presentation

- Full feature display as per below diagram with dimensions of 47.875" width x 16" depth
- Full vendor takeover of the section is allowed
 - Category sign, 16" high, must be included in the display
 - Triple slotted uprights span 96"h from base deck with spacing at 48" on center.
- Display can be branded to vendor's discretion. Lighting can also be incorporated into the display with power cord exiting from the rear (See Display Requirements - Power & Lighting)
- Vendor to include price tag location in design
- Any display signage should reference the entire Best Buy assortment online at Bestbuy.ca and should be approved by Best Buy

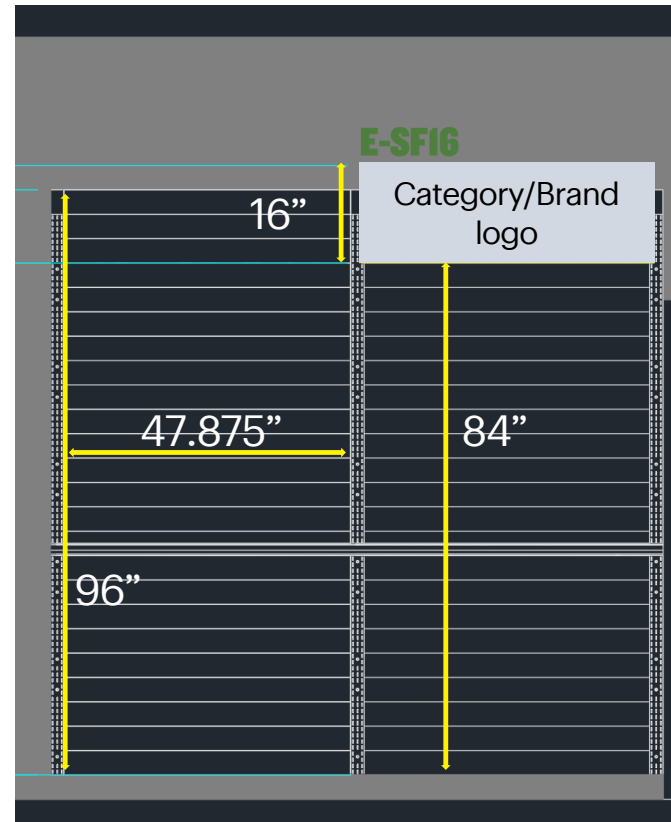
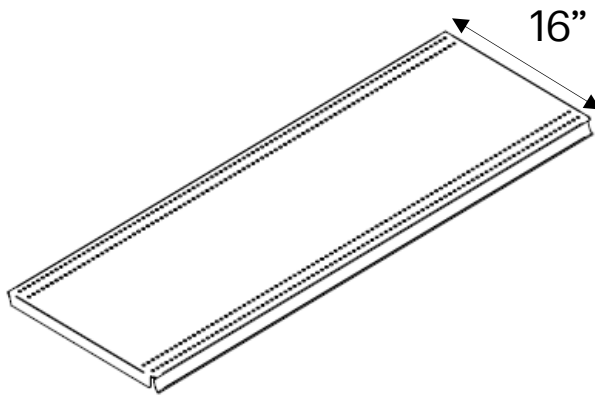

Slotted Upright Detail

- Applicable to all perimeter Best Buy Express sections

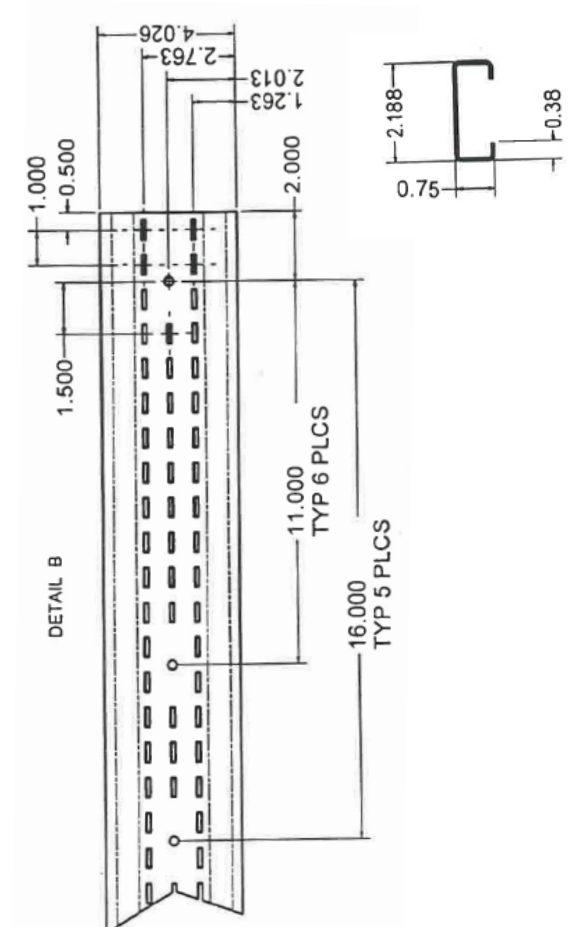

Best Buy Express- Perimeter

Display presentation

- Full feature display as per diagram with dimensions of 47.1875" wide x 16" deep
- Overall display height will vary based on use of EXISTING store base decks or using BUILT-IN base decks
 - Displays using store base decks will need to be 8'1"
 - Displays with built in base decks will have an overall display height of 8'1" + 7" base deck
 - Levelers to be added
- Full vendor takeover of the section is allowed
 - Category sign, 16" high, max depth of 6" - must be included in the display
- Display can be branded to vendor's discretion. Lighting can be incorporated into the display with power cord exiting from the rear (See Display Requirements - Power & Lighting)
- Vendor to include price tag location in design
- Any display signage should reference the entire Best Buy assortment online at Bestbuy.ca and should be approved by Best Buy

no built in base

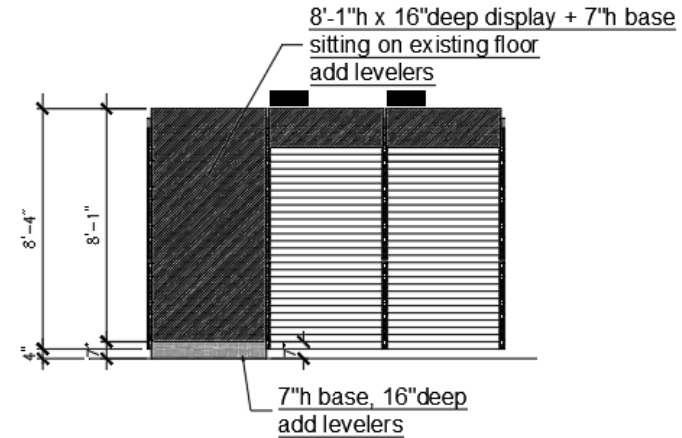

built in base

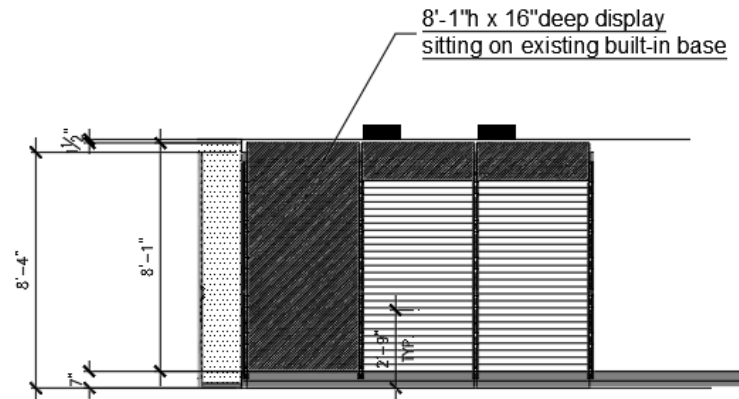

Slotted Upright Detail

- Applicable to all perimeter Best Buy Express sections
 - 16GA steel

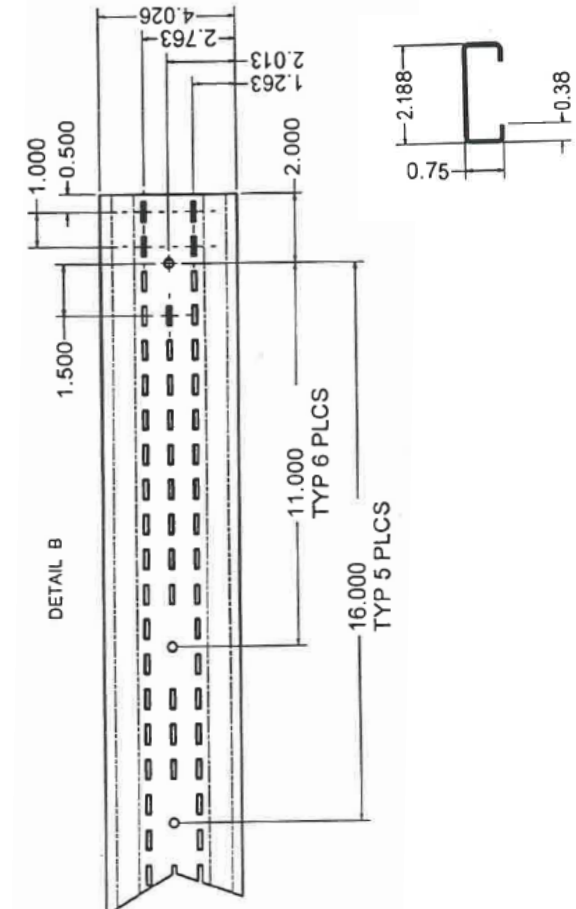

Best Buy Express- Hardware Shelf

Display presentation

- Perimeter location only
 - See previous pages for perimeter wall sizes
- Full feature display as per above diagram with dimensions of 47.25" length x 12" depth x 12" height
- Vendor to include in design price tag location
- Any display signage should reference the entire Best Buy assortment online at [Bestbuy.ca](https://www.bestbuy.ca) and should be approved by Best Buy



Best Buy Express- Headphones and Portable Audio

Display presentation

- Each vendor to provide display headphones and/or portable speakers for placement in acrylic display boxes
- Earbud display box and over ear display box options
- Full section dimensions are 47.25" wide x 12" deep
- Vendor to include in design price tag location
- Confirm signage requirements with PM
- Any display signage should reference the entire Best Buy assortment online at [Bestbuy.ca](https://www.bestbuy.ca) and should be approved by Best Buy

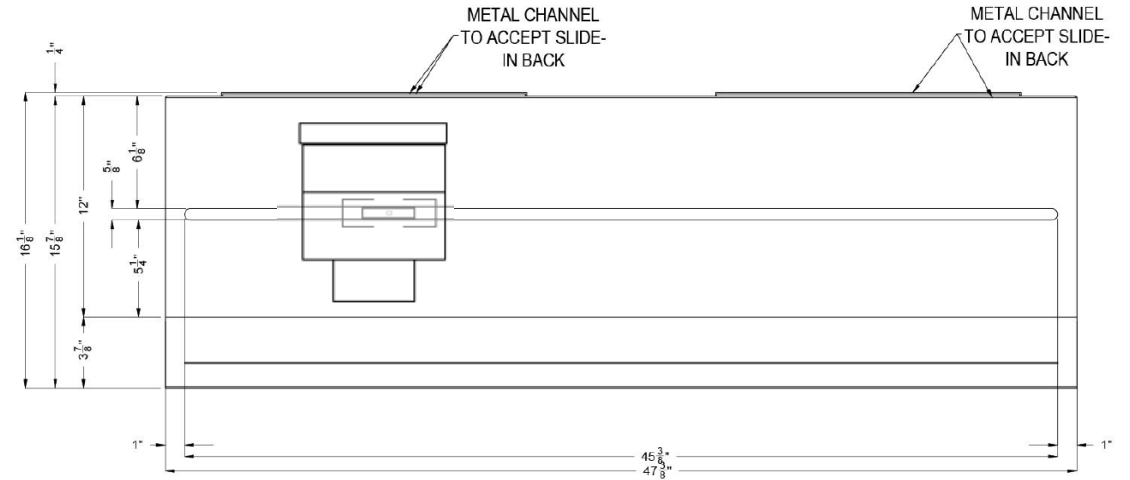
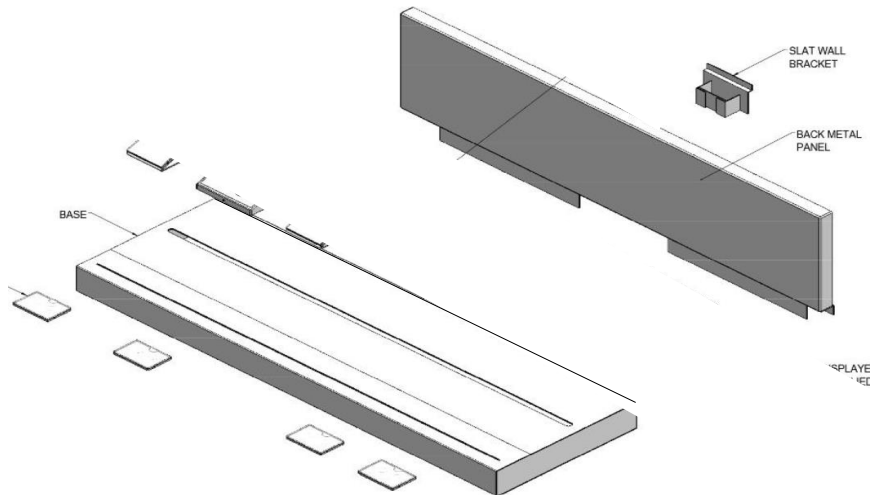

**Let's
talk about
what's
possible.™**

Appendix

French Language Guidelines

The province of Quebec is one of our most important markets in Canada with a loyal customer base that visits our stores regularly. As a primarily Francophone market, we do our utmost to serve our customers in their language of choice as well as respect the laws that govern language within the province.

Language policy in Quebec is defined by the Charter of the French Language which confirms the primacy of the French language within the province and the fundamental right of every resident in the province to receive their communication in French. The government office that protects and enforces this charter is the OQLF (Office québécois de la langue française) which regularly sends auditors throughout the province to ensure compliance. Part of their mandate is to ensure that French is the primary language used for commerce and business which extends to signage and displays present in retail stores. Businesses or entities found to be non-compliant may be fined in court for each offence with penalties doubling for repeat offences. Fines range from \$ 1,500 to \$ 20,000 CAD.

The guidelines in this document must be followed in order for our stores to comply with the regulations set forward in the Charter of the French Language, chapter C-11 sections 54.1, 58 and 67. Those guidelines apply for in-store signage and display. There are other guidelines for product packaging and language of operation.

For more details on the Charter of the French Language and the OQLF, please visit the following website:

www.oqlf.gouv.qc.ca

French Language Guidelines- Details

- Quebec French has some differences from Metropolitan French; consider using a Quebec translation agency.
- Company logos that have a registered trademark(®) or a non-registered trademark(™) do not need translation if there is no French equivalent.
- All registered trademark symbols(®) should be replaced with (MD) "marque déposée". Unregistered trademarks (TM) should be replaced with (MC) "marque de commerce".
- English language tag-lines that have a registered trademark(®) do not need a translation but it is advisable to make the effort to have a registered French trademark for Quebec signage and advertising.
- Equivalent French phrases generally run 1.5 times longer than English – expect to adjust graphic layouts as necessary

English

Koodo
Choose Happy™

French

Koodo
Passez à la joie™

French Language Guidelines- Bilingual Signage

- The overall rule is that signage should be totally in French or, if bilingual, French must be predominant.
- In terms of layout, French is either positioned above the English or preceding the English text on the left.
- English text must be smaller and less predominant than the French.
- The English text cannot exceed 70% of the size of the French text.
- Best Buy determines which specific locations qualify to receive bilingual signage and displays.
- Please contact Best Buy Store Design for the latest store locations that are French-only vs. bilingual.
 - Bilingual stores should receive bilingual signage and displays whenever possible.
 - French-only stores may **never** receive bilingual signage or displays.

French must have clear priority in size and in placement:

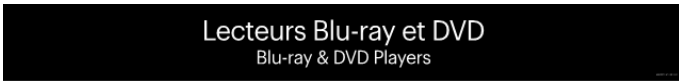

- In this example, French is in a priority position over English and is placed above the text.
- English text is significantly reduced in size; it cannot exceed 70% of the size of the French text



- In this example, French precedes English on the left and English follows on the right.
- English text is significantly reduced in size; it cannot exceed 70% of the size of the French text

Retail Technology Guidelines- Digital Content

Depending on who is distributing your content to the store will determine which checklist you will need to follow”

Vendors follow this checklist if **Best Buy Canada** is distributing your content to stores via our digital network:

- Ensure content follows digital network guidelines and ratings.
- All content must be delivered in English & French.
- Ensure content follows the required tech specs for Best Buy media players.
- Upload content to the Best Buy Canada site (Box- See following pages for instructions).*
- Complete and submit the Digital Content Submission Form for approval.

***Content submitted to Best Buy Canada for approval must be shared via Box or any other approved channel. Please contact your Best Buy Canada Project Manager for upload instructions and additional details.**

All content must be delivered in both English & French

Follow these guidelines when preparing French content:

- All visual elements, on-screen text and graphics, must be in French.
- French content with English music is acceptable.
- Video loops with narration must have narration in the French language. English and French subtitles are not acceptable

Vendors follow this checklist if **You** are distributing your content to stores via your own channels or display:

- Complete and submit the Digital Content Submission Form for approval.
- Ensure content follows digital network guidelines and ratings.
- All content must be delivered in English & French.
- Upload content to the Best Buy Canada site (Box- See following pages for instructions).*
- Complete and submit the Digital Content Submission Form for approval.

The following are **not acceptable** for French content:

- French content submitted with English voice-over or dialogue (it is okay to remove the audio track completely).
- French subtitles added to English content.

Retail Technology Guidelines- Digital Content

Overview:

- Best Buy Canada uses Box.com as a Secure File transfer protocol (FTP) to exchange assets with its external partners. Accessing the Best Buy Canada Box folders is quick and easy and only requires a free box account.

New Box Account:

- When Best Buy Canada shares a folder with external partners, an email notification is sent to the company's representative with an invitation to join a collaboration folder. If your company doesn't currently use Box, you will receive the instructions to create a free, secure account with Box. Follow the steps in the email to create your free account.

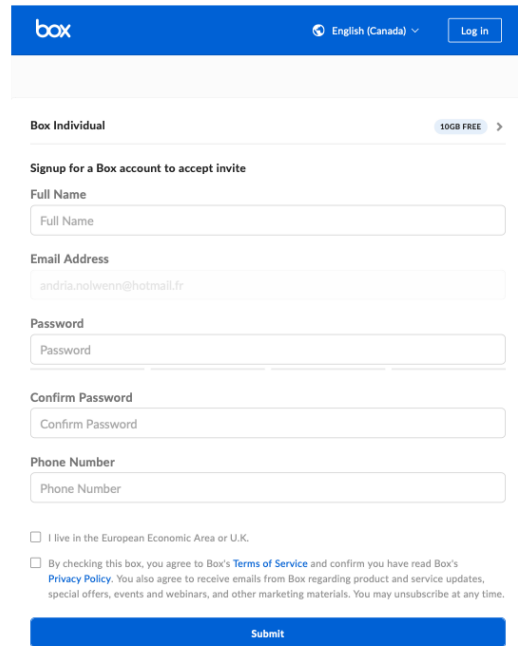

The screenshot shows the 'Box Individual' account creation page. At the top, there is a blue header with the 'box' logo, a language dropdown set to 'English (Canada)', and a 'Log In' button. Below the header, the page title is 'Box Individual' with a '10GB FREE' badge. The main content area is titled 'Signup for a Box account to accept invite' and contains several input fields: 'Full Name', 'Email Address' (with the example 'andria.nolwenn@hotmail.fr'), 'Password', 'Confirm Password', and 'Phone Number'. At the bottom, there are two checkboxes: one for 'I live in the European Economic Area or U.K.' and another for agreeing to Box's Terms of Service and Privacy Policy. A blue 'Submit' button is located at the bottom right of the form.

New Box Account Signup

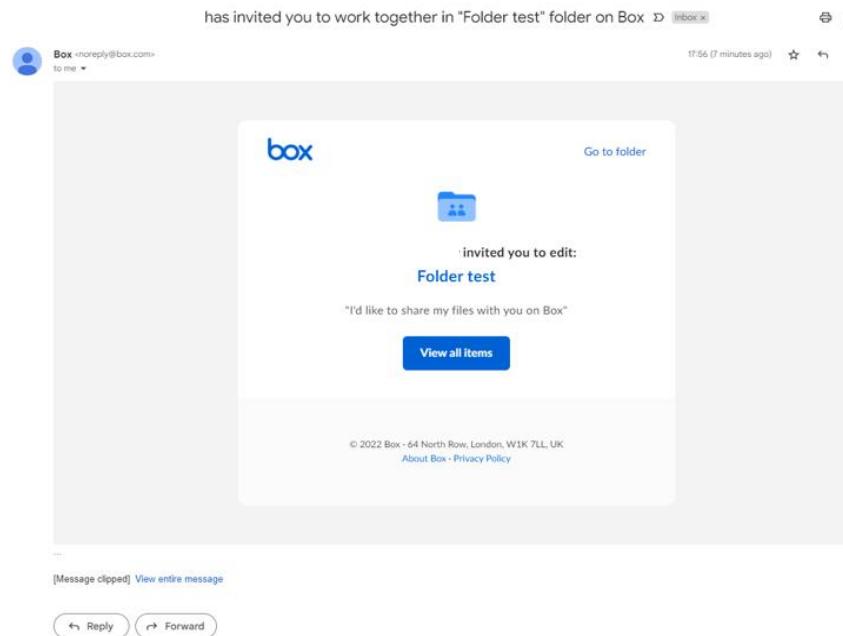

Existing Box Account Invitation

Retail Technology Guidelines- Digital Content

Existing Corporate Box Account:

- If your company already uses Box.com and you have an account, you will receive an email invitation to join the Best Buy Shared folder. Once the invitation is accepted, the Best Buy folder will appear in your main Box page.

Permissions:

- The permission levels are set by Best Buy, and your access will be active for 90 days. After that period, your Best Buy contact will need to re-activate your access.

Logging In:

- When login into Box, external partners must select the “Not a part of Box for Best buy” option.

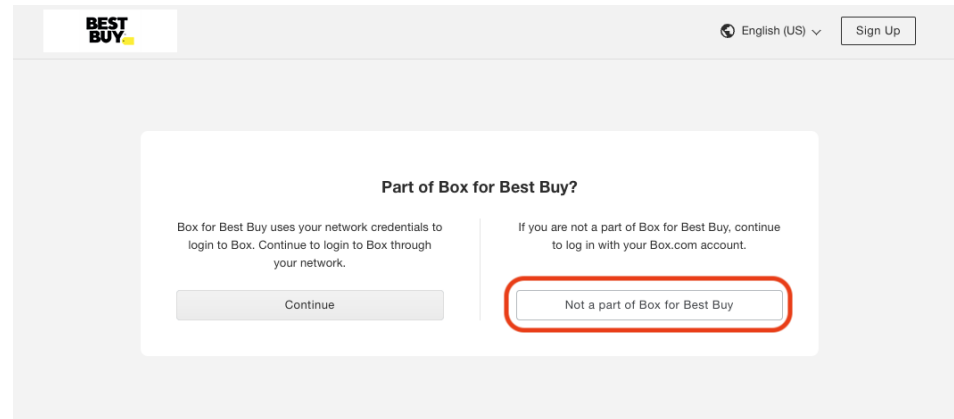

Uploading Files:

- To upload files, select the folder where you would like to upload the files, and simply drag and drop your files.

Support:

- If you have any questions or need help with sharing assets with Best Buy Canada, you can always reach out to our team at ftpsetup@bestbuycanada.ca

Retail Technology Guidelines- Digital Content

Guidelines: The following list presents general themes of concern for Best Buy Canada Ltd. as it applies to visuals and audio. Make sure your content is appropriate for customers of all ages.

Content should not include any of the following	Messaging should not include any of the following
Violence or tasteless imagery (no blood)	Price points
Vulgar or inappropriate language	Third party URL addresses
Nudity/sexual activity	Competitor claims
Drugs, drug use and/or drug paraphernalia (including smoking)	Sensationalized messaging
Inappropriate religious references or symbols of the occult	Product placement (or advertising) for unrelated products, 3 rd parties or competitors
Anti-social/disparaging demeaning behaviour	

Entertainment & gaming content ratings: Entertainment content must fall within the following ratings and has to follow previously stated guidelines

Film	Games	Television
G – General Audience	EC – Early Childhood	TVC/TVC8 – Children’s Prog.
PG – Parental Guidance	E/E10+ - Everyone	TVG – General Audience
14A – Parental Guidance for children under 14	T – Teen	TVPG – Parental Guidance

Approval process will take longer for content that falls outside of these ratings as it will require edits and review.

Retail Technology Guidelines- Digital Content

Vendors that will have their content distributed to stores via Best Buy Canada:

All content must follow these specifications for playback on Best Buy Canada in-store media players:

- Audio will be turned off in-store. All vendor clips will play video only. Content should still convey its message when viewed without sound.
- Content should be delivered as you want it to play in your channel. It should not have any slates, title screens, or extra blank frames before or after the video. It should fade in and fade out to black.
- No edits will be made by Best Buy Canada
- Check if your channel requires 1080P or 4K Content

1080p Video
Resolution: 1920x1080
Aspect Ratio: 16x9
Bit Rate: 15 Mbps
FPS: 30p
Codec: H.265 HEVC, MPEG-2, MPEG-1, H.264 (MPEG-4, Part 10)
Profile 4.2
Extension: .mp4
Audio: AAC

4K Video
Resolution: 3840x2160
Aspect Ratio: 16x9
Bit Rate: 30-40 Mbps
FPS: 30p
Codec: H.265 HEVC
Profile 5.0
Colour Depth: 8 bit
Colour Sampling: 8 bit – 4:2:0 RGB
Extension: .mp4
Audio: AAC

Display Requirements- Power and Lighting

Power Strips:

- Power strips must be composed of the following:
 - Commercial grade
 - CSA, UL or ETL certified (Commercial UL/ETL preferred)
 - 12 - 15' fully shielded cord
 - Must contain a reset switch
 - Must contain a covered guard over the rocker
 - Switch if it is not enclosed in the display

Extension Cords and Splitters:

- No extension cords, Y-Splitters, or other extra power cables or daisy chaining of power strips within the display. Best Buy will not approve the use of these types of components under any circumstances.

Helpful Power Tips:

- The power strip may need to go through a base-deck hole or be routed through a fixture
- Power must come from the bottom of the display with the option to be fed out the back.
- Confirm with your Best Buy PM the best placement for the power cord as location may depend on fixture type

Lighting:

- LED Lighting is popular and is the only approved lighting for displays in Best Buy. Don't make it super bright, blinking, or strange colors. Please keep the temperature of the lighting to 5500K. All lighting must have CSA, UL or ETL certification.

Light bulbs:

- If your product demo includes a light bulb controlled through an app or panel, you will need to work with Store Design & IT to have the device approved.

Power Supply:

- Vendor to provide 3-Prong 15AMP/ 120V power plugs wherever possible. 20AMP power outlet may not be available in all areas of the store.
- Larger displays may require 20AMP/ 125V power plugs. Confirm with your Best Buy PM for compatibility and electrical scope.

Display Requirements- Audio

Default State:

- Audio on the display should remain silent until a customer is interacting with the display.

Interactive State:

- The following are requirements for all displays
- Audio volume must default to a reasonable 70db or less at 3 feet away, measured using c weighting.
- Volume can increase to maximum or down to minimum via the volume control on product.
- The interactive state of the display must time out after 90 seconds and reset to default audio level.
- Audio should also turn off if the customer interacts with the demo button again.

Helpful Audio Tips:

- Best Buy recommends the vendor create custom firmware to enable demo products to be retail ready.
- If the product resides on a Best Buy owned display, it will require custom firmware.

Device Requirements Regardless of Firmware:

- Always on power state.
- Sleep modes disabled.
- Input source defaults cannot be changed (i.e. 3.5mm AUX and(or) TosLink/digital)
- Volume controls enabled
- All other buttons are disabled on the product.

Best Buy Canada highly recommends that the following applications be used to measure volume levels on your display:

iPhone: NIOSH Sound Level Meter by EA LAB or Android: Decibel X PRO

Display Requirements- Video

Media Players:

- A standard media player will be used to display all digital content in Best Buy Stores.
- The standard media players used by Best Buy Canada are:

Use Case	Media Type	Media Player
Simple Loop	Slideshow, Animation, Video	Brightsign LS Series Models
Complex Interactive	Any	Brightsign XD Series Models
Small (10") Touch Interface	Any	BlueFin Custom LCD

- Any other media device must be approved by Best Buy Canada

All content MUST be approved by the Best Buy Digital Marketing Team prior to deployment in stores.

Content may not be changed at any time prior to receiving approval, regardless of the delivery method.

Content Delivery – Convergent Systems:

- Best Buy Canada has the ability to manage and deploy content automatically via our SageNet System integration.
- The system has the ability to schedule, manage, and publish content throughout our stores, or to specific demographics or geography.
- SageNet has a nominal monthly fee. Please reach out to the SageNet team directly for pricing and capabilities:
 - SageNet
 - Brad Tripp
 - 1-416-567-3790
 - brad.tripp@sagenet.com
- Players not utilizing SageNet for content management may be updated manually via Best Buy Network, or SD card replacement.

Display Requirements- Voice Assisted Demos and QR Codes

Media Players:

- Live Voice Commands **cannot be utilized** in any way to demonstrate a product. Canned demos will always be considered.
- All devices that utilize voice activation, voice commands, or voice recognition must be firmware controlled by a demo mode or retail mode and cannot be activated vocally.

QR Codes:

- QR Codes may be used but must only be linked back to the product page on the Best Buy website
- Permission may be given in certain circumstances to link QR Codes to a certain page. This must be approved by Best Buy Marketing and the Project Manager.

Signage:

- Any display signage should reference the entire Best Buy assortment online at [Bestbuy.ca](https://www.bestbuy.ca) and should be approved by Best Buy Marketing and the Project Manager.



Display Requirements- Daytime Security

- Best Buy uses the latest security solutions from InVue for effective and unobtrusive protection of demo units
- No other security vendors will be considered at this time
- Contact your Best Buy Project Manager for full daytime security specifications



Networking- Best Buy Network

When connecting to the Best Buy network via hardline:

- Wired connections are more reliable and have a minimal chance of interference.
- This wired connection MAY NOT be connected to vendor provided switches, routers, or any device that splits or re-broadcasts the network signal.
- All wired connections require the approval of the Technology group and any end point device must be approved by the Best Buy Security Team for network vulnerabilities.
- If multiple connections are required, work with your Store Design contact to determine feasibility of running multiple network drops or the availability of a Best Buy Enterprise managed switch in your display.
- Vendor to complete IT Provisioning form and submit to PM

When connecting to the Best Buy network via wifi:

- Wired Vendors MAY NOT install or broadcast their own dedicated WiFi under any circumstances.
- No device may act as an independent access point to re-broadcast or extend our WiFi.
- Best Buy utilizes both 2.4GHz & 5.0GHz ranges. All devices must be capable of transmitting their MAC address to register on our wireless network.
- Best Buy does not utilize A, B or AB Wi-Fi frequencies. These frequencies are not available in our stores.
- Any wireless device on the WiFi network must not channel bond.
- It is recommended that a device's wireless capability have the ability to be turned on or off easily.
- All wireless connection requests are to be vetted and approved by our Technology group prior to deployment.
- Best Buy Canada reserves the right to disable or remove any device that is deemed to monopolize bandwidth or cause unnecessary interference.
- Vendor to complete IT Provisioning form and submit to PM

Networking - Content Updates

When updating your content remotely:

- All content updates must be limited to outside of regular business hours, all solutions MUST throttle download speeds at the source to prevent saturation.
- Updates that exceed 300MB/device must be scheduled with the Technology Group Networking team.
- Best Buy Canada does not permit Live Audio or Video streaming of any kind. Vendors wanting to stream content must provision their own dedicated internet connection.
- All content must be approved by the Digital Marketing Team, prior to deployment.
- Best Buy reserves the right to disable or decommission at the expense of the Vendor any devices not in compliance with Best Buy's security and connectivity standards, or that are found to negatively impact our infrastructure or experience.

Networking- Security & Compliance

- Any device connected to the Best Buy network must be vetted by the Best Buy Canada Enterprise Information Protection team for network vulnerabilities prior to deployment. Additionally, software or firmware updates must be approved before they can be applied to any existing device.
- A vendor solution **MAY NOT** in any way store or transmit confidential, sensitive, personal, or any kind of identifying information about Best Buy Canada or its customers, including but not limited to; Pictures, Videos, Names, Addresses, Phone #'s, Emails, Age, or any kind of payment information. This includes capturing and sending a customer an email or text.
- Best Buy Canada reserves the right to disable or decommission, at the expense of the Vendor, any devices not in compliance with Best Buy's security and connectivity standards, or that are found to negatively impact our infrastructure or experience.

Display Maintenance

Display Maintenance and Service Life:

- Vendor shall maintain and support the display so that it is fully functional for its entire service life in Best Buy stores.
- Vendor to submit display maintenance contact information to Best Buy and is responsible for providing any changes in contact information. The same contact information must also be maintained in ServiceChannel.
- Vendor MUST register in ServiceChannel. ServiceChannel will send out notification to Vendors for displays that require maintenance.
- Vendor is responsible for acknowledging, updating, and closing Work Orders within the stated timeline as outlined in the Vendor Display Service Level Commitment.
- Display issues must be resolved by Vendor within 14 days in major markets and within 30 days for all other markets.
 - Best Buy may repair, replace, remove or dispose of the display at the Vendor's sole cost and expense:
 - Additional details can be found in the Vendor Display Service Level Commitment.
 - <https://partners.bestbuy.com/home>



Geek Squad Vendor Display Maintenance Services



Geek Squad Vendor Display Maintenance Services

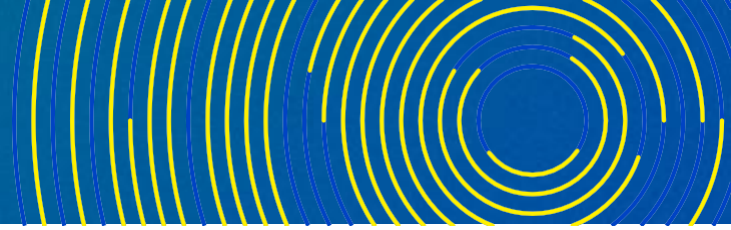

Service Includes:

- ✓ **COMPLETE SCOPE-OF-WORK**
 - Performed by Geek Squad Agents
- ✓ **TROUBLESHOOTING & RESOLUTION**
 - Agents are dispatched and provide quick turnaround times for resolving display issues
- ✓ **REHEARSAL**
 - Select Agents complete a trial install to support on providing an accurate scope of work instructions
- ✓ **SINGLE POINT OF CONTACT**
 - Geek Squad's Internal Affairs team streamlines the service fulfillment process



Geek Squad Vendor Display Maintenance Services

Program Benefits

- ✓ Installation of Demos, Graphics and Parts
- ✓ **4 Audits** and **2 Refreshes** annually
- ✓ Unlimited Service Channel tickets
- ✓ Diagnostic and Troubleshooting
- ✓ Simple annual enrollment
- ✓ Consistent, predictable billing

**Each Display
\$20
Per Month**

*Display maintenance service does not include initial deployment of a display. Geek Squad also supports initial install & testing of new displays on a custom quote project basis (details provided upon request).

*Rate above is for standard support and may vary depending on complexity of the display's design.

*Price in \$CAD

*Please contact Geek Squad's Internal Affairs team at InternalAffairs@GeekSquad.ca with display details for service rates/options.



Geek Squad Vendor Display Maintenance Services – Audits/Refreshes

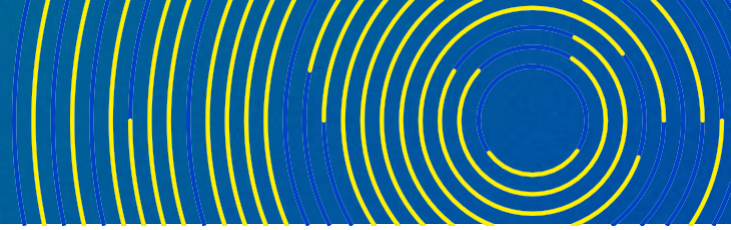

AUDITS
4/year



- Proactively validate functionality
- Create tickets to address deficiencies
- Be ready for peak selling times

REFRESHES
2/year



- Swap demo products, replace worn equipment and update audio & video content
- Includes installation and testing of functionality
- Keep your displays up to date with the newest products

*Three weeks advanced notice requested for all audits and refreshes

*Significant display retrofits are beyond the scope of included refresh work and would be quoted on a project basis.

*One period of end-of-calendar-year blackout period implemented.

*Please contact Geek Squad's Internal Affairs team at internalaffairs@geeksquad.ca and your Category Leader for more details.

Geek Squad Vendor Display Maintenance Services – Repairs & ServiceChannel Tickets

TICKET CREATED

1. Store staff or Geek Squad identifies display failure or deficiency
2. ServiceChannel ticket opened to notify Geek Squad



TROUBLESHOOTING

1. Geek Squad Agent is dispatched
2. Performs troubleshooting
3. Attempts repair



PARTS

1. If parts required, Geek Squad contacts vendor and arranges shipment
2. Ship parts direct to store

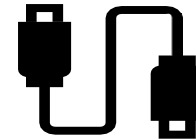

REPAIR

1. Geek Squad Agent repairs display
2. Updates ServiceChannel ticket with service notes and closes ticket

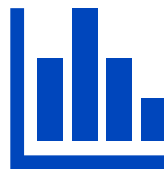
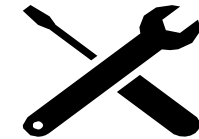

REPORTING

- Weekly reporting on open tickets and ticket resolution

Vendor Display Installation Services



Geek Squad Vendor Display Installation

Program Benefits

Offers a complete solution for display installations from start to finish

- › Involves careful installation, demolition, removal, rebuilding, merchandising and troubleshooting for vendor displays in stores.
- › The additional services include, but are not limited to:

Low Voltage Lighting

Flooring

Lighting Signage

Pac Poles

Cabinetry

Vinyl Repair

Scaffolding

Security

Mounting

Additional Program Benefits include:

FIRST HANDS-ON:

Complete rehearsals, review prototypes and test displays by our professional and experienced Geek Squad agents.

FULL SCOPE OF WORK:

Support with Scope of Work creation and implementation

FRENCH TRANSLATION:

Geek Squad Internal Affairs team will translate the scope of work to French.

A SINGLE POINT OF CONTACT:

Geek Squad's Internal Affairs team supports on each phase of the display's life from installation to maintenance and updates

**BEST
BUY**^{TM/MC} 

